

**PUNTATRICI A BRACCIO OSCILLANTE MEDIA FREQUENZA**  
**MEDIUM FREQUENCY ROCKER ARM SPOT WELDERS**  
**MITTELFREQUENZ PUNKTSCHWEISSMASCHINEN**



**PX1700PRO MFDC**



- Robusta struttura meccanica;
- Portalettrodi ed elettrodi raffreddati ad acqua;
- Bracci regolabili in profondità.
- Rugged steel frame;
- Water-cooled electrode holders and electrodes;
- Arms adjustable for depth.
- Starke mechanische Struktur;
- Elektrodenrager und Elektroden wassergekuhlt;
- Arme verstellbar fur Tiefe.

## BSP INVERTER



### PX1700PRO MFDC

Controllo di saldatura display grafico per il comando di generatori inverter media frequenza  
 Welding control with graphic display for the control of medium frequency inverter generators  
 Schweisteuerung grafische Darstellung fur die Steuerung des Inverters Medium Frequenzgeneratoren

CARATTERISTICHE TECNICHE	TECHNICAL DATA	TECHNISCHE DATEN		BSP 136 INVERTER
Potenza nominale al 50%	Nominal power @ 50% duty cycle	Nennleistung 50% ed	kVA	35
Potenza nominale al 20%	Nominal power @ 20% duty cycle	Nennleistung 20% ed	kVA	55
Corrente di corto circuito	Maximum short circuit current	Max Kurzschlussstrom	kA	20
Forza agli elettrodi 6 bar con l=300mm	Electrodes force 6 bar with l=300mm	Elektrodenhub 6 bar mit l=300mm	daN	275
Tensione di alimentazione (*)	Supply voltage (*)	Primarspannung (*)	V	3x400
Frequenza (*)	Frequency (*)	Nennfrequenz (*)	Hz	50/60
Fusibili ritardati	Delayed fuses	Sicherung	A	32
Scartamento e	Throat gap e	Armaabstand e	mm	220
Max profondita utile l regolabile	Max useful depth l adjustable	Max Ausladung l Einstellbar	mm	700 (min 410) 500 (min 260)
Diametro bracci	Arms diameter	Durchemsser Arme	mm	45
Apertura elettrodi	Electrodes stroke	Elektroden Hub	mm	6-50
Peso (con bracci 400mm)	Weight (with 400mm arms)	Gewicht (mit 400mm Armen)	Kg	125

\* Altre tensioni-frequenze a richiesta / Other voltages- Frequency on request / Sonderspannungen oder Nennfrequenz auf anfrage

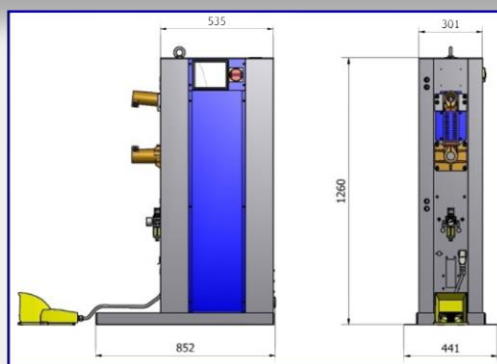
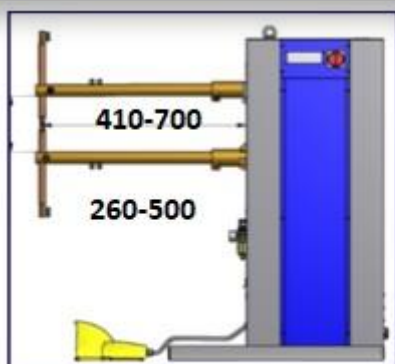
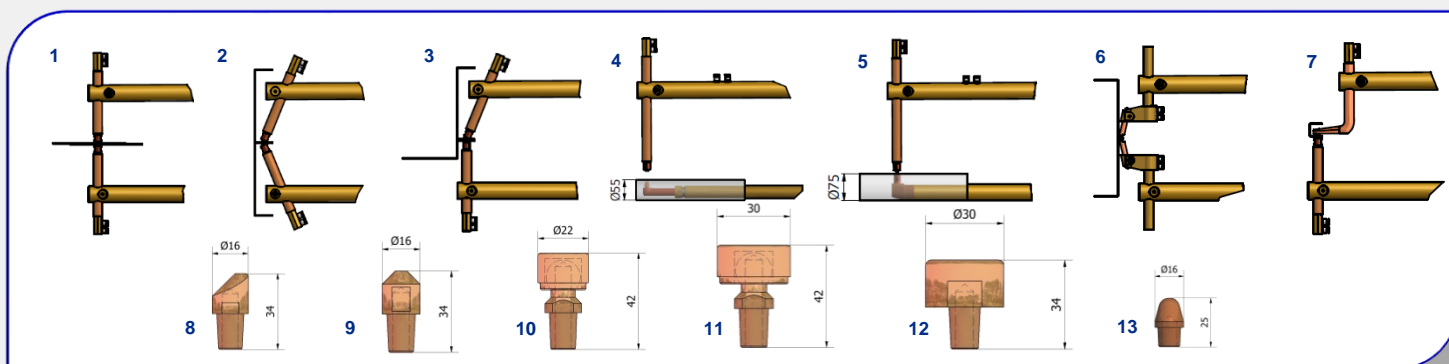

P.E.I.-POINT si riserva il diritto di modificare le specifiche senza alcun preavviso  
 P.E.I.-POINT reserve the right to modify specifications without prior notice  
 P.E.I.-POINT behalt sich das Recht die spezifischen ohne Benachrichtigung zu ndern vor